

Soft Starter (SMC 33 / three controlled phases)

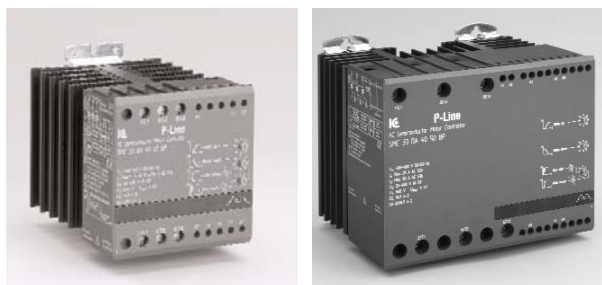

- Rated operational voltage up to 600 VAC 50/60Hz
- Rated operational current up to 86A (inside delta DBP)
- Output signal for By-Pass and Start/Stop
- Ramp Up and Down time adjustable
- Initial Torque adjustable with kick start
- Wide control voltage range
- Meets EN 60947-4-2 requirements
- High number of start/stop operations pr. hour. See data.

Item selection and technical specifications (see also motor table at page 11)

Load ratings AC-53a without by-pass AC-53b with by-pass 1 ^{Inside delta configuration}	Item number by 208-240VAC 50/60Hz Line Voltage	Item number by 400-480VAC 50/60Hz Line Voltage	Item number by 550-600VAC 50/60Hz Line Voltage	Ramp- Up / Down adjustment	Torque adjustment	Module- width
15A AC-53a	SMC 33 DA 2315	SMC 33 DA 4015				90 mm
17A AC-53a no by-pass	SMC 33 DA 2325BP	SMC 33 DA 4025BP				90 mm
25A AC-53b w. by-pass	SMC 33 DA 2325BP	SMC 33 DA 4025BP		Ramp-up time 0.5 - 30 sec.	0- 85% adjustable of nominal torque with selectable kick start 200ms (break loose function)	90 mm
35A AC-53a no by-pass	SMC 33 DA 2350BP	SMC 33 DA 4050BP	SMC 33 DA 6050BP			180 mm
50A AC-53b w. by-pass	SMC 33 DA 2350BP	SMC 33 DA 4050BP	SMC 33 DA 6050BP			180 mm
Items for inside delta configuration				Ramp-down time 0.5 - 60 sec.		
1 ²⁹ A AC-53a no by-pass	SMC 33 DA 2340DBP	SMC 33 DA 4040DBP				90 mm
1 ⁴³ A AC-53b w. by-pass	SMC 33 DA 2340DBP	SMC 33 DA 4040DBP				90 mm
1 ⁶⁰ A AC-53a no by-pass	SMC 33 DA 2385DBP	SMC 33 DA 4085DBP	SMC 33 DA 6085DBP			180mm
1 ⁸⁶ A AC-53b w. by-pass	SMC 33 DA 2385DBP	SMC 33 DA 4085DBP	SMC 33 DA 6085DBP			180mm

Load specified with utilisation category AC-53a

SMC 33 DA XXXX **BP** AC-53a: No by-pass contactors is necessary during running, shall be connected as inline configuration

SMC 33 DA XXXX **DBP** AC-53a: No by-pass contactors is necessary but motor shall be connected in an inside-delta configuration

Load specified with utilisation category AC53b

SMC 33 DA XXXX **BP** AC-53b: By-pass contactor shall be used for bypassing the soft starter during running, shall be connected as inline configuration

SMC 33 DA XXXX **DBP** AC-53b: By-pass contactor shall be used and motor connected in an inside-delta configuration

Output load specification (90mm module) more info page 37

Overload current profile AC-53a (without by-pass contactor)	X-Tx:6-5 : 100-120
Overload current profile AC-53b (with by-pass contactor)	X-Tx:5-5 : 30
Overload relay trip class AC-53a/AC53b	10 or 10A
Leakage current: 5mA ACmax.	Min. operational current: 50mA

Output load specification (180mm module) more info page 37

Overload current profile AC-53a (without by-pass contactor)	X-Tx:6-6 : 100-120
Overload current profile AC-53b (with by-pass contactor)	X-Tx:6-6 : 30
Overload relay trip class AC-53a/AC53b	10 or 10A
Leakage current: 5mA ACmax.	Min. operational current: 50mA

Control terminal specifications

Control voltage by line voltage 208-240VAC A1-A2	24 - 230 VAC/DC
Control voltage by line voltage 400-600VAC A1-A2	24 - 480 VAC/DC
Pick-up voltage max.	20.4 VAC/DC
Drop-out voltage min.	5 VAC/DC
Max. control current for no operation	1mA
Response time max.	70msec.
Control current / power max.	15mA / 2VA

Auxiliary contacts

Terminal: 13-14, AC SCR output for start/stop function,
Terminal: 23-24, AC SCR output for connection of by-pass contactor.

Output specifications for 90mm module: AC SCR: 0.5A AC-14, AC15
24-230/480V AC 50-60Hz Fusing: gl/gG Max i^2t 72A²Sr

Output specifications for 180mm module: AC SCR: 1.0A AC-14, AC15
24-230/480V AC 50-60Hz Fusing: gl/gG Max i^2t 72A²Sr

Terminal: 11-12, have no connection with the internal circuit. Can be used in conjunction with a thermal overload protection or for other wiring purposes. See under general technical information.

Thermal specification

Power dissipation for continuous operation PDmax	3 W/A without BP
Power dissipation with semiconductor by-passed	5 W Max. with BP
Cooling method	Natural convection
Mounting	Vertical +/-30°
Operating temperature range EN 60947-4-2	-5°C to 40°C
Max. operating temperature with current derating	60°C
Storage temperature EN 60947-4-2	-20°C to 80°C

Operation in ambient temperatures exceeding 40°C is possible if the power dissipation is limited either by reducing the steady-state current or by reducing the duty-cycle of the soft starter as shown in the table. Max.cycle time 15min.

By 40°C	By 50°C	By 60°C
100% load Duty-cycle 100%	80% load Duty-cycle max. 0.8	70% load Duty-cycle max. 0.65

Specifications are subject to change without notice

Soft Starter (SMC 33 / three controlled phases)

Wiring specifications (90mm module)

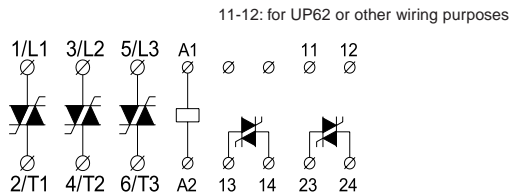

Control voltage: A1-A2
Output 13-14: For control of Start/Stop function
Do not include SMC 33 DA XX15

Output 23-24: By end of ramp up time for by-pass contactor
Do not include SMC 33 DA XX15

Wiring specifications (180mm module)

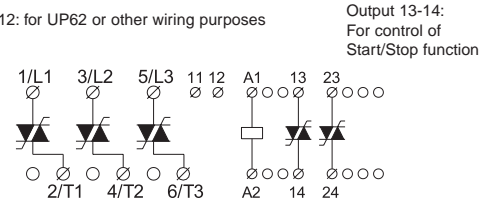

Control voltage: A1-A2
Output 23-24: By end of ramp up time for by-pass contactor

Wiring information: Delta configuration

Standard wiring of a softstarter to a 3-phase motor in delta configuration.

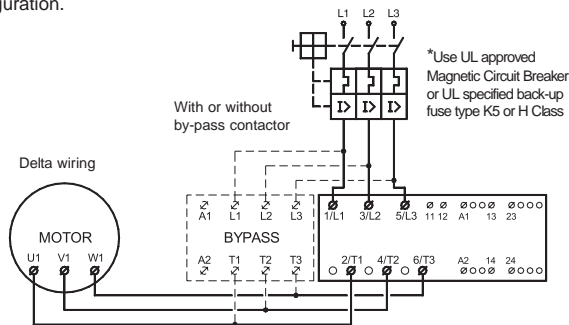

Wiring information: Inside-delta configuration

Inside-delta wiring of a softstarter to a 3-phase motor.

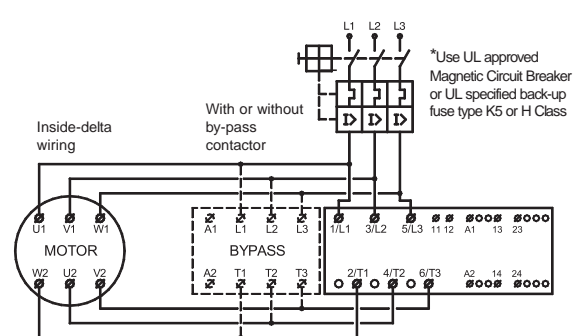

Wiring example Start/Stop - By-pass (90 mm modul)

Auxiliary SCR output contact 13-14 (AC voltage only) is used for controlling a Start-Stop function directly wired to the soft starter. Auxiliary SRC output contact 23-24 (AC voltage only) is activated when the ramp-up time has elapsed. Is used for by-passing the soft starter with an external connected electromechanical contactor.

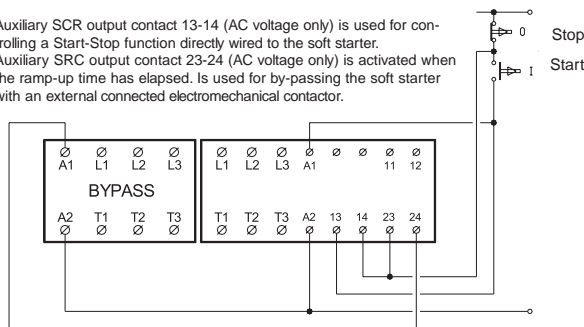

Wiring example Start/Stop - By-pass (180 mm modul)

Auxiliary SCR output contact 13-14 (AC voltage only) is used for controlling a Start-Stop function directly wired to the soft starter. Auxiliary SRC output contact 23-24 (AC voltage only) is activated when the ramp-up time has elapsed. Is used for by-passing the soft starter with an external connected electromechanical contactor.

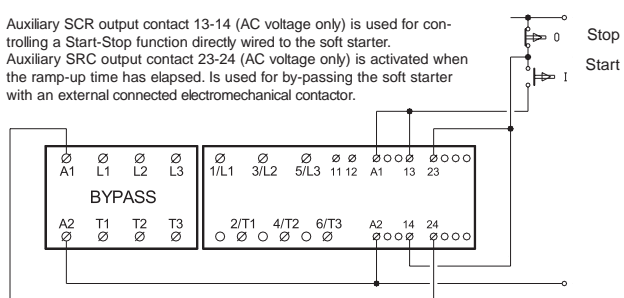

Short-circuit protection by circuit breaker or fuses

Two type of short-circuit protection can be used:

- Short-circuit protection by circuit breaker.
- Short-circuit protection by fuses.

Short-circuit protection is divided into 2 levels **Type 1** or **Type 2**

Co-ordination Type1: Short-circuit protects the installation

Co-ordination Type 2: Short-circuit protects the installation and the semiconductors inside the motor controller

a) Short-circuit protection

Co-ordination type 1 will be obtained when using magnetic circuit breakers or standard gI/GI fuses.

Co-ordination type 2 will be obtained when using semiconductor fuses. When using semiconductor fuses the SCR will not be damaged due to transients and short circuits. The table indicates suitable fuses for co-ordination type 2 protection.

b) Short-circuit protection by fuses

Type 1: SMC 33 DA XX15	Protection max. 50 A gL/gG
Type 1: SMC 33 DA XX25 BP	Protection max. 80 A gL/gG
Type 1: SMC 33 DA XX40 DBP	Protection max. 80 A gL/gG
Type 1: SMC 33 DA XX50 BP	Protection max. 125 A gL/gG
Type 1: SMC 33 DA XX85 DBP	Protection max. 125 A gL/gG

Type 2: SMC 33 DA XX15	Protection max. i^2t of the fuse 1800 A ² S
Type 2: SMC 33 DA XX25 BP	Protection max. i^2t of the fuse 6300 A ² S
Type 2: SMC 33 DA XX40 DBP	Protection max. i^2t of the fuse 6300 A ² S
Type 2: SMC 33 DA XX50 BP	Protection max. i^2t of the fuse 25300 A ² S
Type 2: SMC 33 DA XX85 DBP	Protection max. i^2t of the fuse 25300 A ² S

Fuses from e.g. Ferraz, Siba, Bussmann can be used as short-circuit protection Type 2

More information concerning Co-ordination Type 2 see page 37

Approval

cUL Std No. 508 Pending

Application, adjustment hints and general specifications

See page 10-11 / 36-37