

PROGRAMMABLE MULTITURN ABSOLUTE ENCODER, PHO5 SERIE, POSI+™

- Through shaft \varnothing 14 mm
- Robustness and excellent resistance to shocks / vibrations
- High performances in temperature -20°C to $+85^{\circ}\text{C}$
- Isolated SSI interface, clock from 100 to 500 kHz
- Universal electronic circuits from 5 to 30Vdc
- Protection against short-circuits and inversion of polarity
- High resolutions available: 8192 (13 bits) per turn, and turn counting up to 65 536 (16 bits)
- 2 inputs : DIRECTION and RAZ
- Type choice of the wished limit value : position, rotation speed, temperature
- Diagnostic functions: temperature, rotation speed, position, input/output level
- Programming of the encoder with a serial transmission RS232 directly with the serial PC connection: resolution, number of turn, output code, parity, SSI frame bit number, reset value, functions of the 2 outputs : (OUT 1 and OUT 2): limit switch, incremental channels

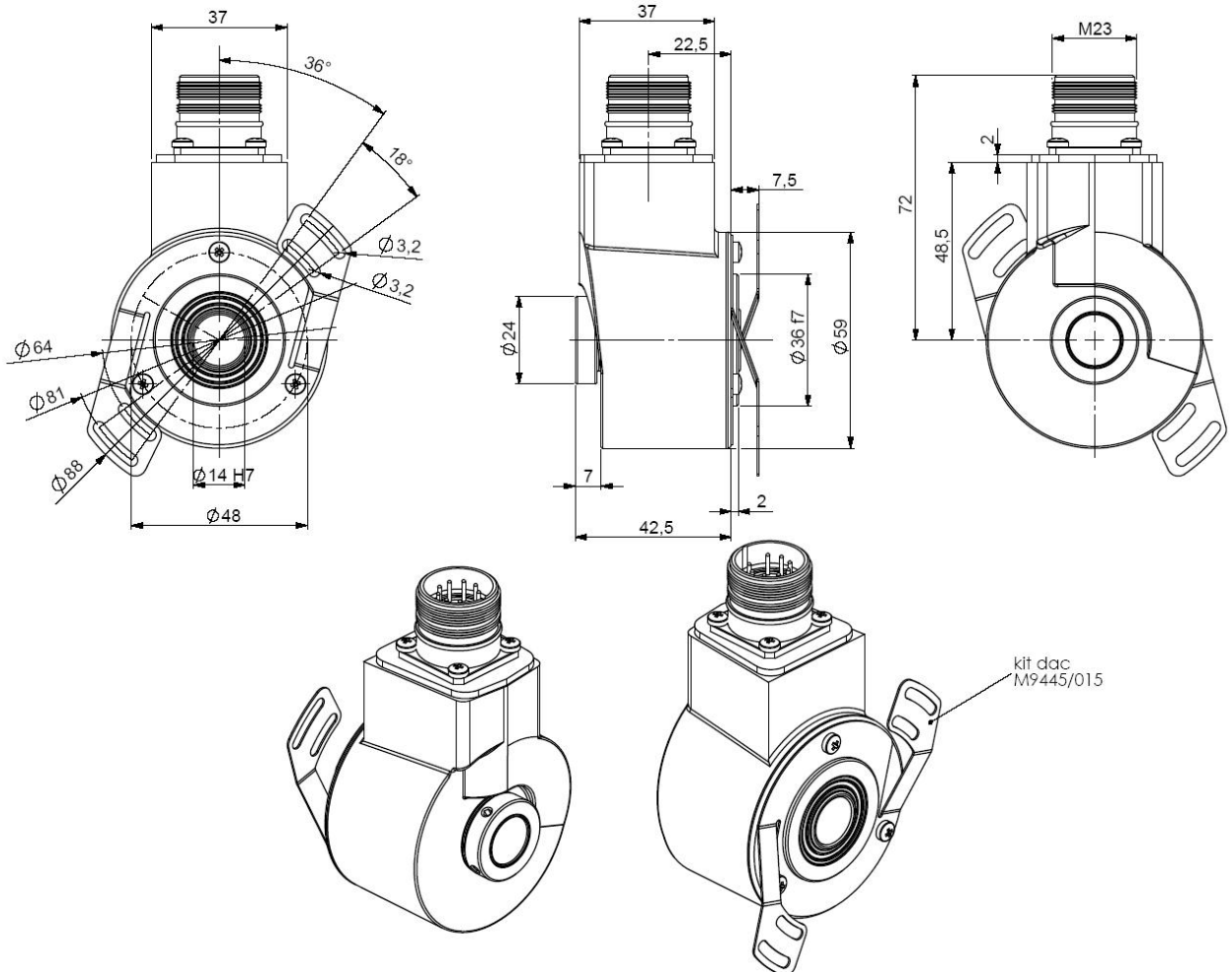

PHO5_14 connection P6R (M23 radial), DAC 9445/015 mounted on the body



Material	Cover : treated steel	Shock (EN60068-2-27)	$\leq 500\text{m.s}^{-2}$ (during 6 ms)
	Body: aluminium	Vibration (EN60068-2-6)	$\leq 100\text{m.s}^{-2}$ (10 ... 2 000 Hz)
	Shaft : stainless steel	EMC	EN 61000-6-4, EN 61000-6-2
Bearings	6 803 serie	Isolation	100V (1 min)
Maximal load	Axial : 20 N	Weight	0,480 kg
	Radial : 50 N	Operating temperature	$-20 \dots +85^{\circ}\text{C}$ (encoder T°)
Shaft inertia	$\leq 2,2 \cdot 10^{-6} \text{kg.m}^2$	Storage temperature	$-20 \dots +85^{\circ}\text{C}$
Torque	$\leq 6 \cdot 10^{-3} \text{N.m}$	Protection(EN 60529)	IP 65
Permissible max. speed	$6\,000 \text{min}^{-1}$	Torque (ring pressure screw)	nominal: 1.5N.m, break: 2.0N.m
Continuous max. speed	$6\,000 \text{min}^{-1}$	Theoretical mechanical lifetime 10^9 turns ($F_{\text{axial}} / F_{\text{radial}}$)	
Shaft seal	Viton	10 N / 25 N : 185	20 N / 50 N : 24

PROGRAMMABLE MULTITURN ABSOLUTE ENCODER, PHO5 SERIE, POSI+™

In order to optimize the installation times of SSI encoders, BEI IDEACOD has developed a friendly software, easy to use, with which it's possible to program your encoder under WINDOWS in only 2 minutes. With a simple connection to the serial connector of your PC, you can :

- configure : the number of points per revolution, the number of turns, the code type, SSI frame bit number, the parity, reset value
- read : type of selected encoder, the serial number of the encoder, the position of the encoder, the temperature, the speed of rotation, the level of the input/output
- save the chosen configuration, load saved configurations
- function of the outputs and limit value : position, speed of rotation, temperature, incremental channels 2048 ppr

ELECTRICAL CHARACTERISTIC

Input signal clock CLK	per opto-coupleur	Power supply	5 - 30Vdc
Output signal DATA	line - driver selon RS422	Introduction	< 1 s
Clock frequency CLK	100kHz - 500kHz	Cons. without load	< 100mA (typically 60-70mA at 24Vdc)
Precision	± ½ LSB (13 bits)	Position refresh	< 200µs

SSI TRANSMISSION

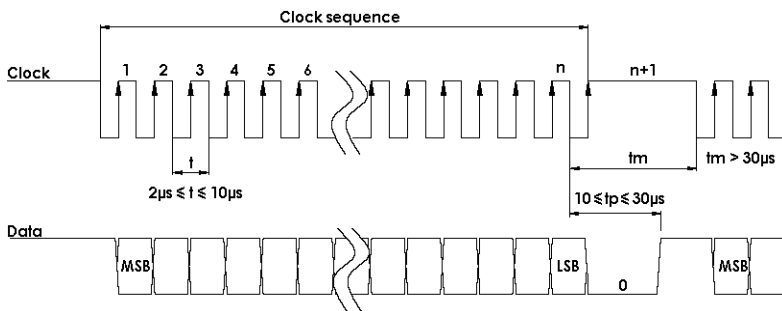

Transmission	Transmission up to 400m at 100kHz in function of the cable characteristic
Cable	High security of transmission by using shielded cable and twisted pairs

SSI CONNECTION

Type	Vcc	Gnd	Clk+	Data+	RAZ	Data-	Clk-	DIR.	OUT1	OUT2	TXD Encoder RXD RS232	RXD Encodeur TXD RS232
P6	1	2	3	4	5	6	7	9	10	11	8	12

The pinouts TXD and RXD entries used for the encoder programming
Connect the entry DIRECTION and RAZ to a potential (RAZ to the 0V if not used)

Data output RS422

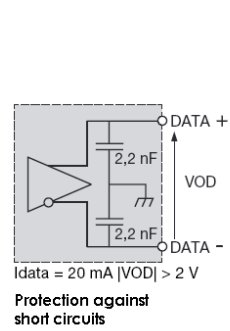

Isolated Clk input

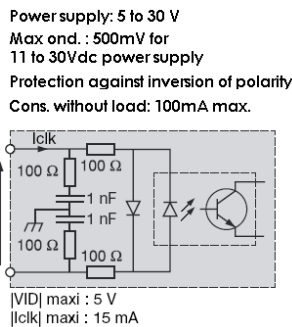

DIRECTION input

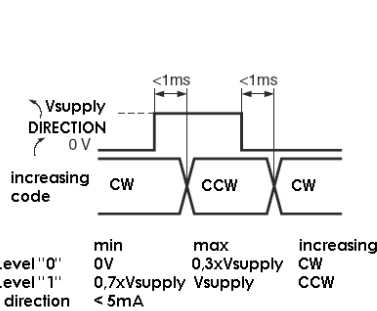

RAZ / RAX input

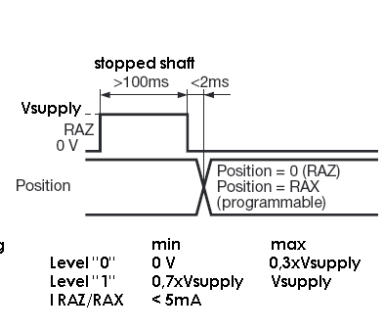

- Output :**
- Max current: 20mA
 - Level "0" max : 0.5V, Level "1" min : Vsupply-2,5V
 - Limit switch time answer : < 400µs
 - Incremental channels : 100kHz max

Programming cable : PC RS232

- Supply : 230Vac / 12Vdc
- Cable SubD9 (serial PC) / M23 12 pins (encodeur)
- Reference : PRO-020S001

ORDERING REFERENCE (Contact the factory for special versions, ex:special flanges, connections, electronics...)

	Shaft Ø	Supply	Output stage	Code	Resolution			Connection	Orientation
PHO5_	14:14mm	P : 5 to 30Vdc	PX : SSI programmable Nota : without parity by default	G : Gray default	13 B12 D5			P6: M23 12pins CW for SSI transmission	R : radial
					Resolution	Nb of turn	Nb data		
					13: 13 bits default	B12: 12 bits default	D5: 25 bits default		
PHO5_	14 //	P	PX	G //	13	B12	D5 //	P6	R

SOFTWARE / CONFIGURATION MANUAL: consult us