

PRELIMINARY - PARALLEL SINGLE TURN ABSOLUTE ENCODER, CHM5 RANGE, POSI+™ CE

POSI+™, the new generation of parallel absolute single turn encoders :

- Robustness and excellent resistance to shocks / vibrations
- High protection level IP65, IP67 feasible with a sealing flange
- High resolutions, up to 15 bits (gray or binary)
- Universal electronic circuits from 5 to 30 Vdc
- High performances in temperature -20°C to 90°C (option -40°C to 100°C)
- Standard DIRECTION entry, LATCH option



CHM5_10 connection C3R (radial cable)

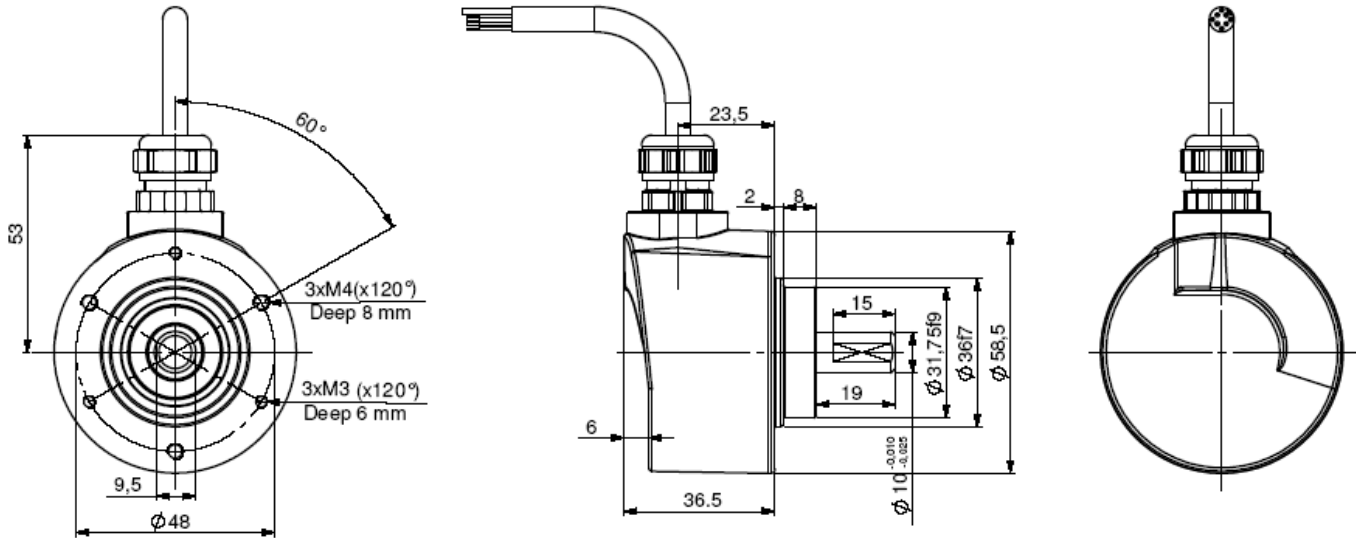

CHM5_06 connection CPR / C1R (radial M23), with flange 9500/003 mounted on the body

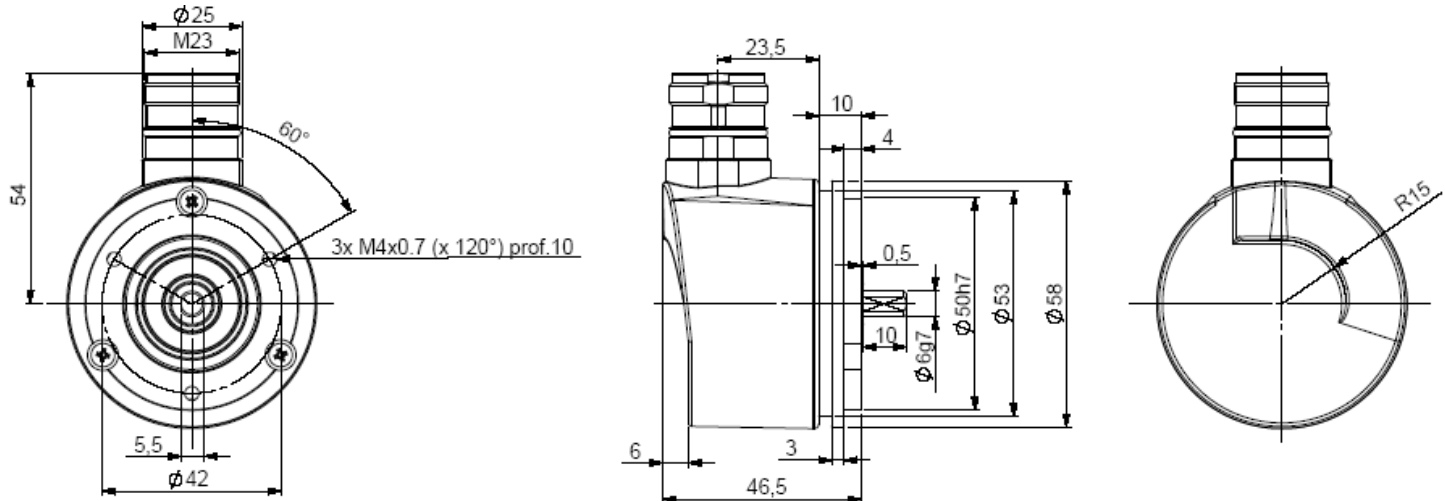

Material	Cover : zinc alloy	Shock (EN60068-2-27)	≤ 500 m.s ⁻² (durant 6 ms)
	Body: aluminium	Vibration (EN60068-2-6)	≤ 100 m.s ⁻² (10 ... 2 000 Hz)
	Shaft : stainless steel	EMC	EN 61000-6-4, EN 61000-6-2
Bearings	6 000 serie	Isolation	1 000 Veff
Maximal loads	Axial : 50 N	Weight (connector)	0,3 kg
	Radial : 100 N	Operating temperature	- 20 ... 90°C (encoder T°)
Shaft inertia moment	≤ 1.10 ⁻⁶ kg.m ²	Storage temperature	- 40... + 100°C
Torque	≤ 4.10 ⁻³ N.m	Protection(EN 60529)	IP 65 (IP67 with flange option)
Permissible max. speed	12 000 min ⁻¹	Theoretical mechanical lifetime 10 ⁹ turns (F _{axial} / F _{radial})	
Continuous max. speed	9 000 min ⁻¹	25 N / 50 N : 99	50 N / 100 N : 12

PRELIMINARY - PARALLEL SINGLE TURN ABSOLUTE ENCODER, CHM5 RANGE, POSI+™ CE

CONNECTION

	color	13 bits + direction CP or C3	14 bits + direction C1
1	white WH	0V	0V
2	brown BN	+Vcc	+Vcc
3	green GN	D0	D0
4	yellow YE	D1	D1
5	grey GY	D2	D2
6	pink PK	D3	D3
7	blue BU	D4	D4
8	red RD	D5	D5
9	black BK	D6	D6
10	violet VT	D7	D7
11	white/brown WH/BN	D8	D8
12	white/green WH/GN	D9	D9
13	white/yellow WH/YE	D10	D10
14	white/grey WH/GY	D11	D11
15	white/pink WH/PK	D12	D12
16	white/blue WH/BU	DIRECTION	D13
17	white/red WH/RD	/	DIRECTION

ELECTRONIC

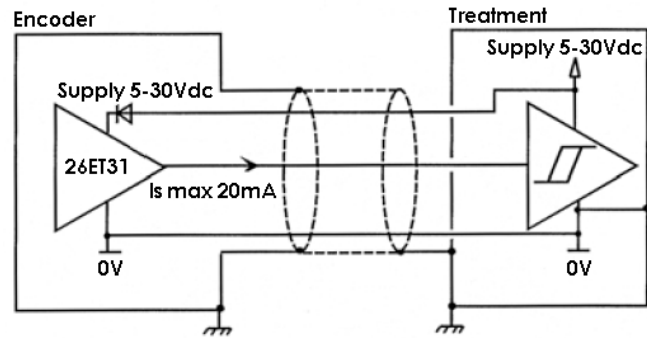

Power supply : 5 to 30Vdc
Consumption without load : 100mA max
Current output per channel : Is=20mA max
Level "0" (Is=20mA) max : V_{ol} = 0,5Vdc
Level "1" (Is=20mA) min : V_{oh} = Vcc-2,5Vdc

Protection against short circuits and inversion of polarity

DIRECTION

CW increasing code: DIRECTION pin to +Vcc
CCW increasing code : DIRECTION pin to 0Vdc

LATCH (option)

Active data on the outputs : LATCH pin to 0V
Frozen data on the outputs: LATCH pin to +Vcc

Consult us for the connection of an encoder with this option

Example, 10 bits encoder : only MSB will be supplied (D3 to D12)

ORDERING REFERENCE (Contact the factory for special versions, ex: special flanges, connections, electronics...)

	Shaft Ø	Supply	Output stage	Code	Resolution	Connection	Orientation
CHM5	10 : 10mm	P : 5 to 30Vdc	C5 : push pull 5 to 30Vdc	B : Binary G : Gray	Power of 2:	CP : M23 16 pins 13 bits + direction C1 : M23 17 pins 14 bits + direction	R : radial
	1: 1 bit to 14: 14 bits						
	06 : 6mm				Max: 15 bits Consult us	C3 : 16 wires cable with cable gland output	Example : R020 : radial cable of 2m
CHM5	_ 10 //	P	C5	_ G //	13 //	C3	R050

Monitoring function available in option :

- of the code coherence
- of the LED internal regulated current loop
- of temperature range with 2 limits

Entry / output available in option:

- LATCH entry
- ERROR output for monitoring functions

Consult us